

MODEL : SC-209 [Flange Swing Check Valve]

Connection : Flange JIS 10K, PN 16 | 40



VTV VALVE, serving Multi-National end users in a wide range of applications in many industries including:

1. Palm Oil and Refinery Plant
2. Food Industries
3. Petrochemical Plant
4. Cooling System
5. Fire Protection System
6. Power Plant
7. Water Treatment Plant

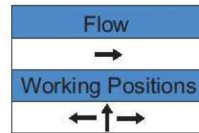

- ◆ Suitable for : 1. Water
- 2. Oil

◆ SPECIFICATION

Valve Design : DIN 3840
 Face to face : DIN 3202
 Flanges : DIN 2501
 : DIN 2547
 : DIN 2526 FORM E
 : BW TO DIN 3239
 Testing : DIN 3352 Part 1
 : DIN 3230 Part 3

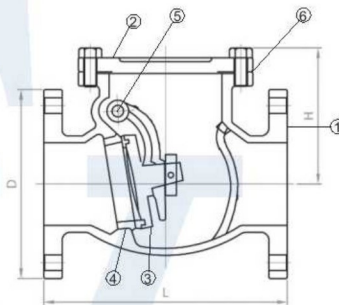

◆ PRESSURE / TEMPERATURE RATING

JIS 10K : 10 bar - 120°C | 7 bar - 200°C | 5 bar - 300°C
 PN 16 : 16 bar - 120°C | 13 bar - 200°C | 10 bar - 300°C
 PN 40 : 36 bar - 120°C | 33 bar - 200°C | 27 bar - 300°C

◆ MATERIAL LIST

ITEM	PART NAME	MATERIAL			
1	BODY	FC200	GS-C-25	SS304	SS316
2	COVER	FC200	GS-C-25	SS304	SS316
3	DISC	SS410	WCB + 13%CR	SS304	SS316
4	SEAT RING	SS410	A105 + 13%CR	SS304	SS316
5	HINGE	DUCTILE	WCB	SS304	SS316
6	GASKET	GRAPHITE	GRAPHITE	GRAPHITE	GRAPHITE

◆ DIMENSIONS (mm)

DN	40	50	65	80	100	125	150	200	250	300
	1-1/2"	2"	2-1/2"	3"	4"	5"	6"	8"	10"	12"
L	190	203	220	240	292	330	356	495	622	698
H	100	105	115	140	155	170	203	246	283	330
D	140	155	175	185	210	250	280	330	400	445
Weight (Kg)	17	17.6	20.5	28	45	60	77	128	199	308